

# Deltec

INSTALLATION INSTRUCTIONS FOR THE DELTEC TWIN-TECH CALCIUM REACTORS



## Introduction

Congratulations on your purchase of a Deltec Twin-Tech Calcium Reactor, described by Reefbuilders as the “Supercar of Calcium Reactors”

These instructions will guide you through the installation and running of your new reactor with tips and advice for getting the most from your unit

## Models, tank size and overall footprint

- **CR Twin-Tech 1500** – for aquariums up to 1,500 litres – 310 x 180 x 590 mm
- **CR Twin-Tech 3000** – for aquariums up to 3,000 litres – 390 x 240 x 590 mm
- **CR Twin-Tech 10000** – for aquariums up to 10,000 litres – 440 x 300 x 920 mm

## Principle

This latest generation reactor operates on the principle of total CO<sub>2</sub> saturation by the continuous recirculating of the water in the reactor through a large bubble of gas.

The CO<sub>2</sub> dissolves in the water until it is fully saturated, which occurs at a very low pH, at which point no further gas can be dissolved until additional water is added to the reactor.

The whole process is controlled automatically by the digital controller and float switch in the gas chamber. As the CO<sub>2</sub> bubble dissolves in the water, the water level rises, which raises the float switch and triggers the solenoid valve to add more gas to replenish the bubble.

## Features

This innovative reactor has several unique features providing simplicity of control but also relating to the way that the system feeds the reactor with water from the aquarium.

The smart controller on the Twin-Tech uses a flow meter to accurately measure the volume of water passing into the reactor, it uses this information to control a standard DC feed pump.

This feature allows the user to know exactly how much reactor effluent, in litres, is being added to the aquarium within each 24-hour period, which is shown on a large LCD display in the centre of the controller. The water flow can be adjusted by the user between 3 and 350lt per day simply by pressing two up and down buttons on the panel.

## Contents

The reactor as standard consists of the following items. (There are some small variations between models)

- 1 – Large media chamber.
- 2 – Smaller gassing chamber with float switch.
- 3 – Controller with separate power supply unit.
- 4 – Recirculation pump and connections.
- 5 – Feed pump with suction filter.
- 6 – Low voltage solenoid valve.
- 7 – Hoses and non-return valves to connect the unit.

## Not included

- 1 – CO<sub>2</sub> bottle, CO<sub>2</sub> pressure reducer and CO<sub>2</sub> hose.
- 2 – Calcium reactor media.

**Recommendation:** ROWA lith W, Grain size: 12-16 mm or an other medium in the grain.

**Needs a filling:** CRTT 1500 5,5 kg, CRTT 3000 13,5 kg, CRTT 10000 30 kg

- 3 – Controller holder
- 4 - Power supply unit for the 10 V interface

## Connections and general layout

Use the following diagram as an overview to allow you to connect the reactor together. Details of assembly are given in the text.

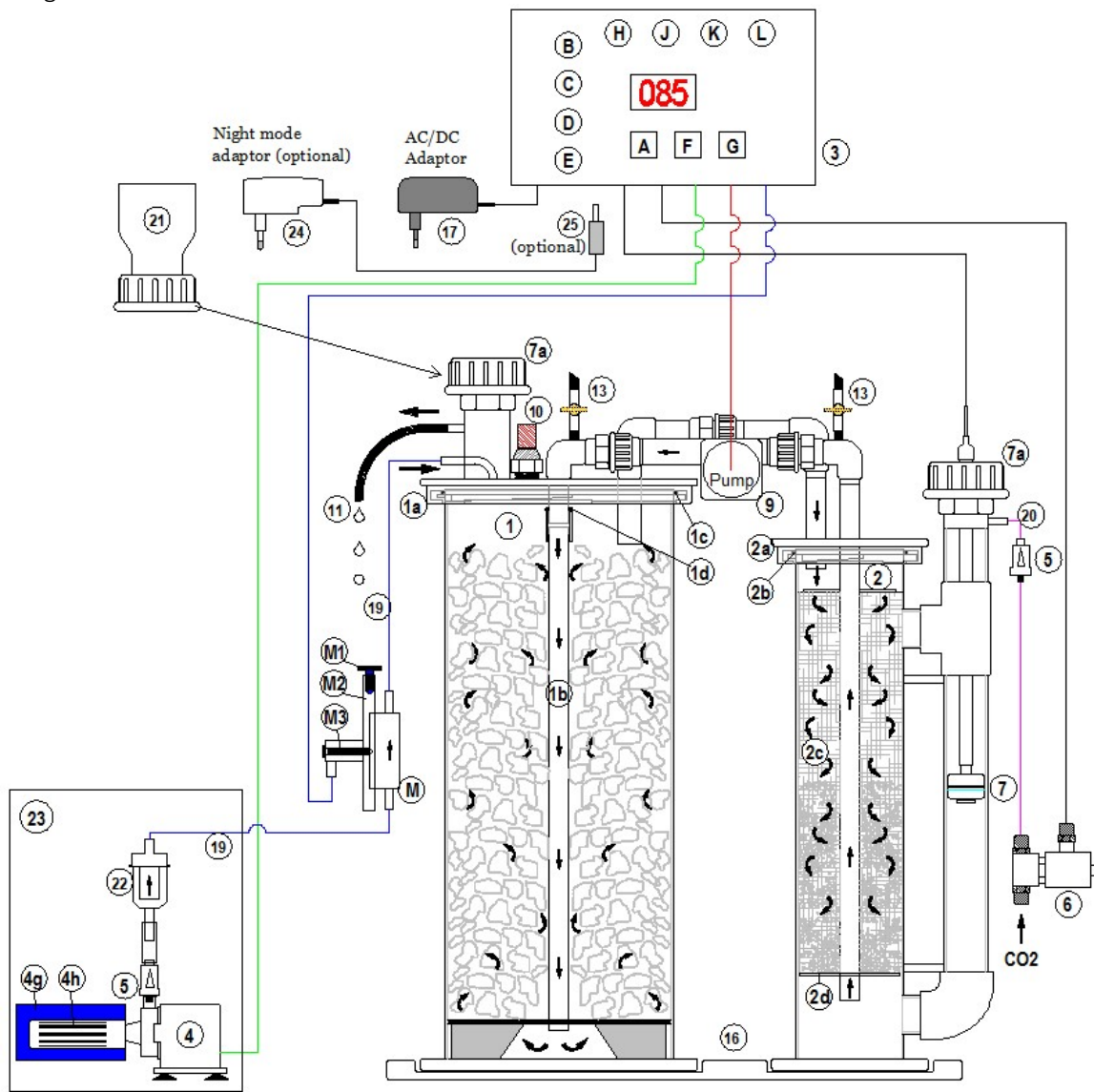

### Key

1. Media chamber
2. Gassing chamber
3. Control unit
4. Feed pump
5. Non-return valve
6. Solenoid valve
7. Float switch
8. CO2 bottle and Regulator
9. Recirculation pump
10. PH probe position
11. Outlet from reactor
12. Top-up fill cap for media
13. Bleed valve
15. CO2 feed to gassing chamber
16. Base plate
17. Power supply to controller
18. Optional timer system

### Control Functions

- A – Mode button
- B – Water flow rate per 24 hours in litres\*
- C – Degassing after 'X' litres\*
- D – Recirculation pump speed %\*
- E – Process active/complete %
- F – Increase button for items marked \*
- G – Decrease button for items marked\*
- H – Activity indicator green/yellow/red
- J – CO2 valve open/active
- K – CO2 Bottle empty (audible alarm)
- L – Degassing cycle running

## Assembly of the reactor

**Step 1** – Positioning. Choose a suitable place to position the reactor so that you have easy access to all parts for operation and for maintenance, especially the media chamber for topping up.

You must also decide where to position the controller relative to the reactor. This should be quite close to the aquarium or sump taking into account the length of hose and cable runs.

The two halves of the reactor are located in position on a custom base plate to space the 2 chambers apart.

**Step 2** - Starting with the media chamber, take off the lid by rotating the top section anticlockwise using the 2 handles. Note that after running, the lid may become harder to open and so 2 clear pipe handle extensions have been supplied to provide better leverage. These should not be used to overtighten the lid.

**Step 3** - Some early versions of the reactor were supplied with a sponge at the bottom of the media chamber. This is not required and should be removed.

**Step 4** – Pre-wash the media to remove any fine dust and add to the media chamber, filling to within 2cm of the return suction pipe on the lid. Ensure that no media goes down the centre pipe by using the handy blanking cap attached to the outside of the lid and keep the pipe in the middle of the reactor whilst filling.

*Note: You have an option to fill the larger media chamber with water at this stage whilst the lid is removed.*

**Step 5** – Replace the lid on the media chamber, having first checked that the large O-ring is in place on the top of the main tube. The lid is then rotated clockwise to lock in place by hand. Do not over tighten.

**Step 6** – The 2 reactor chambers are held together at the top by the recirculation pump assembly. Check that the two O-rings are in position on the pipe unions then screw the pump assembly onto the two reactor chambers and tighten hand tighten the unions. (image 1).



Image 1

**Step 7** – For this reactor you will need a Co2 bottle, 2 stage Co2 regulator and Co2 tubing. Connect the regulator to the bottle and Co2 hose from the regulator to the solenoid valve taking care that the flow is in the correct direction as indicated by the arrow.



Image 2

Connect a second CO2 hose from the other side of the solenoid to the Co2 connection of the float switch as shown in image 2, ensuring that a non-return valve is fitted in line just before the reactor.

### IMPORTANT:

- 1 – Always use specific CO2 hose with this reactor.
- 2 – Keep the distance between the regulator and the solenoid as short as possible, ideally less than 30cm.
- 3 – Ensure that a non-return valve is fitted between the solenoid and the reactor.
- 4 – Check the CO2 system for leaks by brushing soapy water around the joints when under pressure.

### Step 8 – Connecting the feed pump.

The unit is fed with tank water using a small DC feed pump which is supplied with the system. The pump is fitted with a sponge pre-filter before the pump and a fine filter and non-return valve after the pump. It is important that these are installed and maintained to prevent water back syphoning from the reactor.

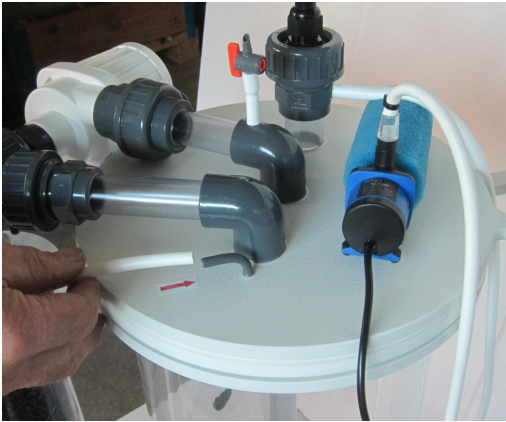

Connect the white feed pump hose to the nipple on the top of the reactor as shown in the image to the left.

Connect the pump power supply cable to the correct port on the control panel as indicated by a coloured tape band on the pump connector.

### Step 9 - Connecting the controller

The controller has five connections as shown below and numbered on the general layout diagram on page 2 of these instructions.



#### Connections

- Power supply
- Auxiliary power supply (option)
- Solenoid jack port and cable
- Feed pump connection (yellow line)
- Recirculation pump connection (red line)
- Flow meter connection

Connect the cables and pumps in the positions shown on the layout diagram on page 2 but **do not** plug the power supply into the mains at this stage.

Each side of the two pump connections are colour coded for ease of identification.

### Step 10 - Filling the reactor with water

At this stage the reactor should be fully assembled and ready for filling with tank water and bleeding.



Replace the knurled cap on the media chamber with the special funnel adaptor as shown in the image. Fill with tank water using a pump and hose or jug through this port. You will need to position the end of the outlet pipe at high level to prevent it draining out during filling.

You can also choose to unscrew the top cap of the float chamber, remove the float and pour water directly into the float and gas chamber however always check that the O-ring is in position before screwing back on the lid when full.

The unit will now be 95% full of water and only the pump and top pipes will still be dry.

### Step 11a – Final bleeding of the pump (manual)

This is potentially the easiest part of the process but can become the most fiddly if not carried out properly.

On the top of the reactor there are 2 bleed ports with orange taps. Ensure that the outlet pipe from the reactor is still positioned above the height of the reactor so that water cannot escape.

Open one of the bleed taps and continue to add water to the funnel until water starts to come out of the bleed tap and then close. Repeat with the other tap.

The unit should now be free of any air.

### Step 11b – Final bleeding of the pump (using supply pump)

An alternative method of bleeding the unit is to use small feed pump to supply water into the reactor to chase out the final amount of air via the control panel (MODE FLOW FUNCTION). This is most useful if you need to re bleed the unit for any reason once you have had it running.

With this method you must replace the funnel with the standard cap and we would recommend extending the length of the bleed nipples with short lengths of hose that extend into a container above the height of the reactor. Put the end of the outlet pipe into the same container.

Apply power to the control panel, set the display to the daily output mode then press the MODE button for 4-5 seconds until the LED screen shows a count. Open one of the bleed taps and wait until water starts to come out of that pipe then close the tap. Repeat with the second bleed valve. Depending on how much air remains in the unit you may need to press the mode flow function repeatedly to expel all of the air.

*A quick tip, which we really should not really recommend, but works especially well on the smaller reactor to remove the last amount of air from the pump body, is to suck on one of the bleed valves. You will get half a mouthful of water, then half a mouthful of air, then water again which is when you close off the tap.*

**IMPORTANT: UNLESS YOU BLEED ALL OF THE AIR FROM THE RECIRCULATION PUMP DURING INSTALLATION THE REACTOR WILL NOT RUN.**

Functions of the Twin-Tech controller, buttons and LED indicators.

The Twin-Tech controller is the brains behind the reactor making it very simple for the hobbyist to use.



You will see that on the controller there is a central LCD display and a number of LED indicators and buttons as shown on the diagram below.

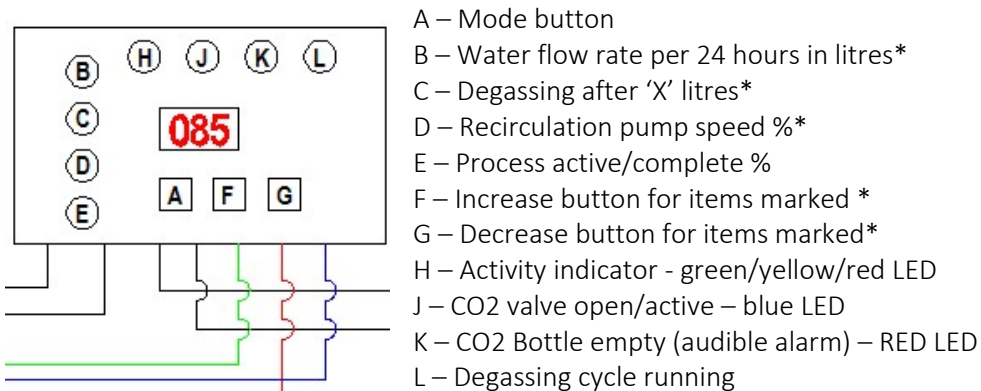

**A – Mode button:** Press and release this button to scroll through the various function displays on the central display. Continued pressing scrolls through these 3 functions in a loop.

- > **Press** – displays reactor output water flow volume per 24 hours in litres. LED B illuminated.
- > **Press** – displays water flow volume between degassing cycles. LED C illuminated.
- > **Press** – displays reactor recirculation speed 0-100%. LED D illuminated.

To adjust the value of functions, press button **F** to increase and button **G** to decrease.

**Mode flow function** - Pressing the mode button for 4-5 seconds when in daily output mode will cause the supply pump to run for a cycle 0-100 and then stop. Press again to reactivate for another cycle.

This is particularly useful for adding small amounts of water to the reactor during the final filling stage.

**B – Water Flow:** The LED display gives a readout of the total water/effluent that passes through the reactor in a 24-hour period, (assumes that the optional timer function is not used), and can be increased and decreased in 1 litre steps from a recommended minimum of 3 litres/day to a maximum of 350 litres/ day

The smart controller calculates and splits the total daily litres required into smaller volumes which are dosed automatically in approximately 5-minute intervals throughout the day using the flow meter.

It is therefore possible to calculate the total dKH required per day and to adjust the levels in the tank by simply increasing or decreasing the total volume of effluent dosed by the reactor.

**C – “Degassing After” volume:** As the media melts in the reactor, air and inert gases that were trapped in the substrate are released. These gases dilute the pure CO2 and reduce the ability of the reactor to maintain a lower pH which gradually rises throughout the day. This can be seen on the pH graph below.

A degassing cycle flushes out all of the gas in the reactor chamber and replaces it with fresh CO2 to maintain the optimum low pH and therefore the maximum output from the reactor.



In general, we suggest degassing only once a day however the chart above is illustrates the pH changes for an aquarium that is being degassed 3 times per day.

**For example:** if the “water volume” is set to 80 litres per day we would suggest that you set the “Degassing After” setting also to 80 litres so that it degasses once per day.

For tanks running easily within the total capacity of the reactor, it is possible to increase this duration and the only reason to de-gas more than once per day would be if the demand was close to reaching the maximum capacity of the reactor.

**D - Recirculation pump speed:** This function allows the user to increase or decrease the recirculation speed of the water around the reactor and is important for a number of reasons:

- The higher flow passes more water over the media which increases the ability to dissolve by preventing localised saturation on the surface of the media.
- Allows fine control of the fine bubble mass in the gas chamber, (discussed later).

As a starting level we would suggest starting at 35% recirculation.

If the flow rate is too high, then fine gas bubbles can be carried over into the media chamber and if recirculation is too low then there is less of a mixing effect of the CO<sub>2</sub> into the water.

**E – “Process Aktive”:** This LED is illuminated to indicate that the feed pump cycle is in operation and is coupled with a count function of the main display from 1-100%.

This counting function will be observed approximately every 5 minutes reflecting the addition of water to the reactor. The speed of the count will be determined by the head pressure of the system and length of feed pipe from the pump but will normally take about 1-2 minutes to complete.

**F, G – Up and down buttons:** These are self-explanatory and used to control the levels up and down of functions B, C and D above.

**H - Activity indicator green/yellow/red:** Indicates the state of the reactor at any time

- Green – normal running state – all OK.
- Yellow – water being added to the reactor, coupled with indicator E and main LED count.
- Red – indicates that the float switch plug has been removed, coupled with a low volume bleep.

**J – CO<sub>2</sub> process active:** A blue LED indicates that the solenoid is open, and the reactor is calling for CO<sub>2</sub>. This will come on during initial filling of the gas chamber and generally comes on for a couple of seconds every time new water is dosed into the system.

**K – CO<sub>2</sub> empty:** A red indicator will alarm if the controller asks for CO<sub>2</sub>, but the float is not triggered within a period of 4 minutes.

This could be for the following reasons:

- The CO<sub>2</sub> bottle is empty or close to empty.
- The solenoid is faulty and not opening to let through CO<sub>2</sub>.
- The pressure or flow rate of the gas is too low, so that on initial starting or following a degas, the gas chamber is not filling within 4 minutes.

**L – De-gas cycle operating:** During the degassing process this LED is illuminated.

### Use of the optional timer function

The pH of nearly all closed aquariums will naturally drop overnight as the photosynthetic processes, which use up CO<sub>2</sub> from the water column, stop. Use of a calcium reactor will conversely add CO<sub>2</sub> to the water and depress the rise in pH during the daylight period.

Some people therefore choose to only run their reactors during the hours that the lights are running to try and level out that pH swing.

To facilitate this, there is a power port to the left of the float switch cable into which a 10V power source can be connected. This power supply can be linked to either a simple timer or to an aquarium computer and used to hold off the reactor from dosing during part of the 24-hour cycle.



When the 10V supply is applied the activity LED H will flash red/green and the controller prevents the supply pump from adding any water to the reactor however all of the other pumps, solenoids and functions continue to operate as normal.

It will be necessary to allow for the hold off period when calculating the flow rate required, for example; if the normal flow rate required was 60 litres per day for continuous running and the reactor was stopped from dosing for 12 hours of the 24-hour period, then it would be necessary to set the flow rate to 120lts.

## Running the Twin-Tech reactor for the first time

You should now be ready to run the reactor for the first time, go through the following checks.

- The unit is completely full of water and bled of any air in the pump.
- The end of the outlet hose is in the sump or tank
- Is the CO2 system connected and the pressure correctly set? If the pressure is too high, the solenoid valve can no longer close and the CO2 bottle is emptied. The pressure should be 0.5 to 2.0 bar (depending on the pressure reducer used). The filling process should take between 5 and 10 seconds..
- AT THIS STAGE LEAVE THE MAIN VALVE ON THE CO2 BOTTLE CLOSED.
- The feed pump is in the tank water. Squeeze the filter sponge to remove any air.
- All wires are connected to the pumps and the float switch is plugged into the controller.
- Set the initial flow rate to 50lt/day
- Set the recirculation rate to 35%
- Set the initial bleed rate to 50lt/day.

### Plug in the power

The main LED will display a series of numbers as the system initiates and then the recirculation pump will start to run.

**IMPORTANT:** At this stage you should be able to observe the water recirculating around the reactor. If this is not the case, then you have not correctly removed all of the air from the recirculation pump body. Remove the power from the controller and bleed the reactor again.

If the water is observed circulating around the reactor then you will also see the blue light on the controller illuminated as the system requests CO2. **Now open the main valve on the CO2 bottle** and you will observe a large pocket of gas starting to form in the top of the gas chamber. This will slowly grow until the bottom of the pocket reaches the level of the float switch and should happen over a period of 60-120 seconds.

If the gas pressure from the regulator is too low so that it takes more than 4 minutes to trigger the float switch, then the unit will alarm. Increase the pressure slightly on the regulator and briefly unplug/re-plug in the controller and it will start again and refill correctly.

If the pressure is too high, then the pocket will fill too quickly which may introduce too much gas in during normal operation when the system is only asking for top up additions.

### The reactor is now running normally.

Observe the system operating and you will see the feed water come on every 5 minutes or so, this will allow the CO2 to dissolve in the new volume of water. The pocket of gas will get smaller until it reaches the upper float position, at which point it calls for more gas, the blue LED will come on as gas is added, refills and triggers the float again, the blue light goes off.

Generally, you will not observe the de-gas cycle operating as it will happen automatically in the background.

### Measuring the dKH of the effluent.

Leave the reactor to run for a couple of hours and then measure the dKH coming out of the effluent. This will normally be in the range of 40-60dKH.

Most test kits only read up to 16dKH for a full syringe of reagent, however if you add a second syringe it is 32dKH, and so on. Keep going until you reach the end point and then all of the numbers together.

An alternative method is to dilute the effluent 1:3 and then multiply the test result by 4 to get the final reading. This method uses less reagent which may be important if testing regularly.

## Calculating the correct reactor effluent flow volume

The flow volume of effluent from the reactor for any aquarium will depend on a number of factors:

- The total volume of the aquarium system.
- The coral stocking density of the aquarium.
- How hard you drive the reactor by adjustment of the recirculation and de-gas functions.

## Measuring the dKH of your aquarium.

It is important before you start, to know the dKH of your aquarium or the target level that you are trying to achieve and maintain.

On day 1, as you switch on the reactor, you may have a dKH of 8.0 and start with an effluent flow of 50lt/day. If, on the second day, having run the reactor for 24 hours, the dKH is 8.2, then you can see that the level is rising and so you know you are adding too much reactor effluent per day. Adjustment is as simple as dialling down the daily flow volume. Try dropping from 50 lt/day to 40lt/day. If on the next day the level still continues to rise, then turn it down further.

If the dKH drops, then increase the flow rate and continue to do so until the level becomes stable, this is now your dialled in flow rate. Set the de-gas volume to be the same.

## Existing calcium reactor

If you are converting from an existing calcium reactor then it is fairly easy to calculate the flow rate required.

Collect and measure the flow rate that the old reactor outputs over a period of 1 hour, multiply x 24 and you know the flow rate per day. Measure the dKH of the effluent, example 85 lt/day at 30dKH.

Multiply the daily volume x the dKH to get the total demand in dKH units per day, in this case  $30 \times 85 = 2550$ .

If the new reactor generates a dKH of 45, then divide the total demand of 2550 dKH units by 45 to get the flow rate for the new reactor of 57lt/day. This is a good starting point and can be adjusted from there.

## Liquid additives

If you know how much dKH you are adding daily from your existing dosing system, then a similar calculation can be carried out to estimate the starting volume.

## Adjustment of CO2 bubbles in the gas chamber and recirculation rate

For the first 3- 4 days of running the reactor, you will see that the bubbles in the gas chamber are quite large and do not extend below the water line. *Image 1*

After that time, you will see that the water entering the gas chamber starts to entrain a lot of fine bubbles which increases the solubility of the CO2 due to the increased surface area. *Image 2*

The depth of the bubbles is adjusted by changing the % recirculation rate of the pump.



*Image 1*



*Image 2*

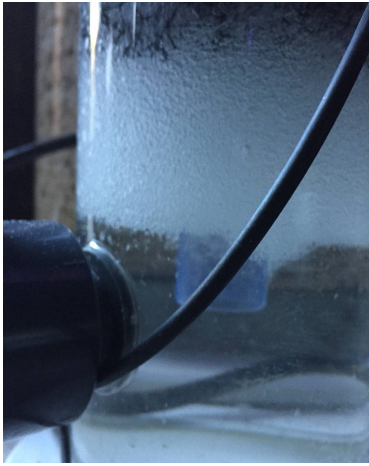

For normal operation, the recirculation speed of the pump should be set so that the fine bubbles pass down the gas chamber and then return to the surface of the gas pocket.

The lower level should be carefully set so that you can still see the central suction pipe and observe that very few bubbles are passing over into the media chamber.

It is not necessary to have the fine bubble rate too low for normal operation as this will use a little more gas as the bubbles pass into the media chamber.

Note that water chemistry changes can also have an effect on how far down the bubbles travel and some days you may see changes in the level without an adjustment of the recirculation rate.

## Measuring the pH within the reactor

It is absolutely not necessary to measure the pH within the reactor as it is not used for control, however it does allow you to understand what is going on as you make small adjustments.

Generally, throughout the day there will be a small rise in pH between degas cycles due to the build-up of inert gas released from the media.

On the chart below you can see the initial rapid drop from normal tank pH as the reactor is first switched on and the 2 peaks B & C, just before each degas cycle.

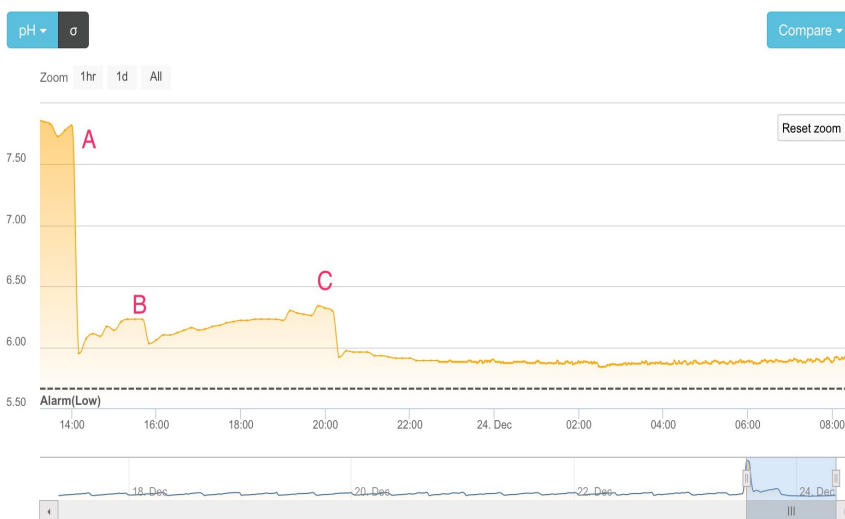

**Overdriving the reactor:** It is also possible to overdrive the circulation rate so that the bubbles are forced down even lower than for the normal running level. In this method, small amounts of fine bubbles are continuously drawn into the central suction pipe and out into the media chamber.

The small amount of lost gas is continuously replaced with fresh CO<sub>2</sub>, thus preventing build-up of the inert or non-reactive gas from the dissolving media within the gas pocket.

This can be observed in the graph above after point C where you can see a constant LOW pH and you would also measure a corresponding higher dKH from the reactor. The pH is then running at a constant 5.8.

Use in this format will allow you to extend the period between normal degas cycles but may also increase the amount of CO<sub>2</sub> used.

Normally it is only necessary to run the reactor this hard if you are nearing its maximum output capacity for your particular aquarium. It is also likely to result in a generally lower pH within the system.

## Maintenance and topping up of media.

It will be necessary to carry out regular maintenance on the reactor and to top up the dissolving media to maintain the optimum functionality over time.

**1 – Topping up of reactor media:** This should be carried out continuously to maintain the same level of media within the reactor. Remember that as the amount of media in the reactor falls, so will the output of dKH in the effluent and so it is important to keep it full.

Fresh media can be easily added whilst the reactor is running by taking off the outlet cap and replacing it with the funnel part. Add the media in slowly by hand and tap the side of the reactor to encourage the fresh media to flow out away from the fill point.

**2– Total media replacement or cleaning:** As the reactor dissolves the media into smaller and smaller pieces there will be some level of restriction to water flow and a build-up of fines in the voids between the chunks.

We therefore recommend that you empty out and rinse the media every 3-4 months to maintain efficiency.

**3 – Cleaning of the feed pump coarse-filter:** This sponge filter prevents debris and larger particles from entering the pump and should be cleaned every month or whenever the flowrate, (count rate), is observed to reduce.

**4 – Cleaning of the fine inline filter:** Similarly, to item 2, this fine filter should be reverse flushed out or replaced every 1-2 months.

**5 – Cleaning of the flow meter:** Over time the flow meter can become calcified or blocked and so we recommend that every 4-6 months that you recirculate a descaling solution, such as D-D Ezyclean through this component and collect into a separate container.

You can either use the supplied feed pump, continuously triggering the pump run function, or another suitable sized pump. Ensure that the descaler is well flushed before reconnecting the back to the reactor.

## Trouble shooting.

**1 – CO2 Bottle empties very quickly:** There is likely to be a leak on one of the joints of your CO2 regulator or a small hole or split in the CO2 hose.

Make a soapy water solution and brush carefully around all of the joints and gauges. If there is a leak, then you will get bubbles forming. Tighten joint, replace hose or apply PTFE tape to threads.

**2 – CO2 Bubble fills to float position and keeps on filling:** This could be due to 2 reasons;

- **Air leak on the gas or float chamber.** As this section is under negative pressure, any untightened caps or missing o-rings will allow air to be drawn in and will continue to fill with air until the pocket of gas reaches the pump and stops recirculation. Check and tighten all joints.
- **Sticking solenoid valve.** If the solenoid valve does not shut off properly then it will continue to fill with CO2 until the pocket of gas reaches the pump and stops recirculation. This could happen quickly or slowly depending on how open the solenoid sticks. Check and clean out solenoid.

**3 – CO2 empty alarm is sounding:** Check and refill CO2 bottle.

**4 – Count on supply cycle slows down:** Check and clean the coarse and fine filters.

**5 – Error code F01 is displayed, a beep sounds, the flow meter counter does not count up.**

Error code F01 is displayed for 30 sec. if after 4 min. and 30 sec. the water filling process is not completed. This process is repeated continuously

- Check and clean the coarse and fine filters.
- The flow meter is blocked and must be cleaned. Follow point 5 in the maintenance section.
- The feed pump is blocked: Open the pump and remove the blockage
- The silicone hose is kinked, eliminate

Further information and hints

For further information or hints, please visit our website at [www.deltec-aquaristic.com](http://www.deltec-aquaristic.com) or email us at [email@deltec-aquaristic.com](mailto:email@deltec-aquaristic.com)

# Spare part list

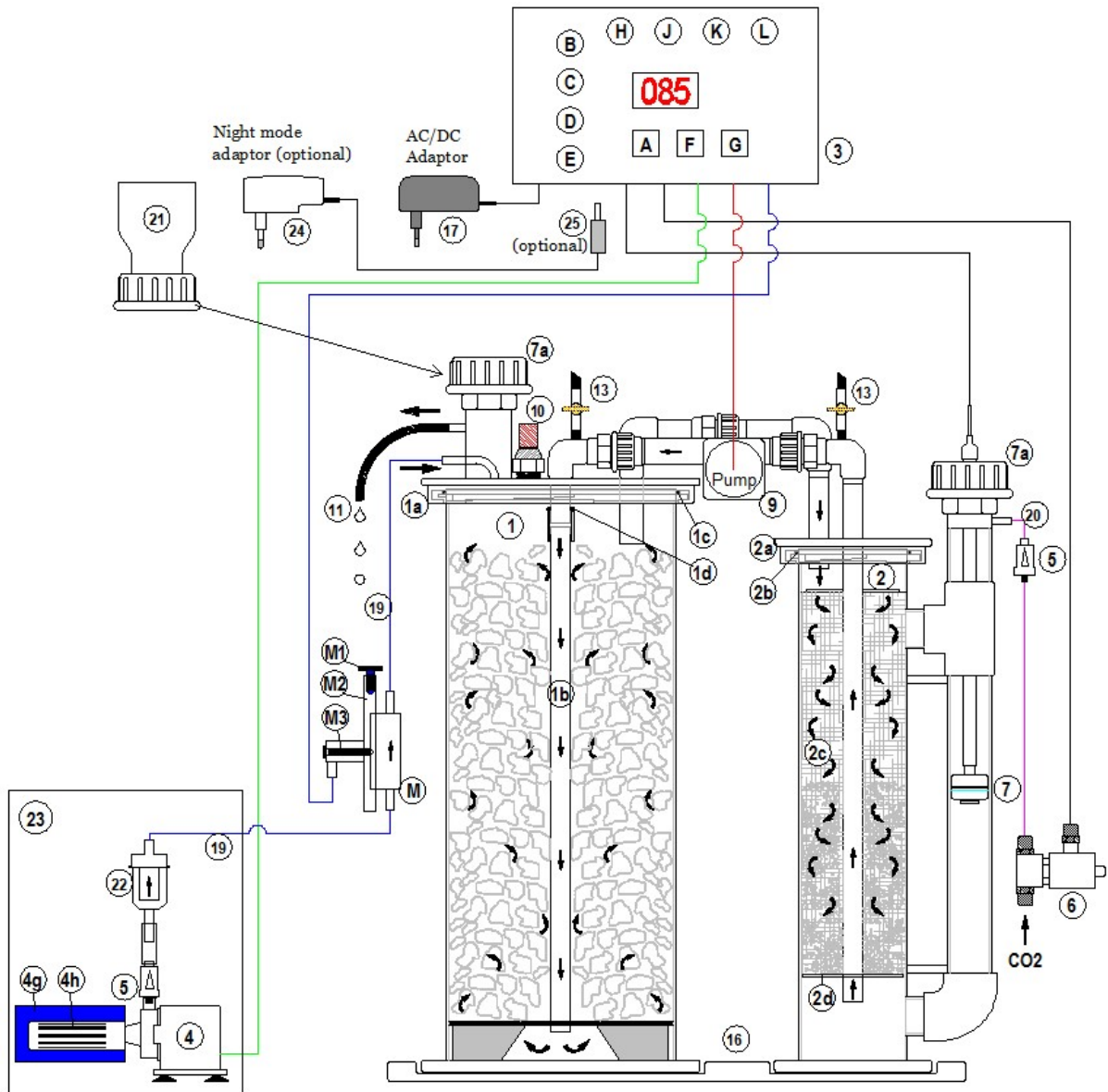

		CRTT 1500	CRTT 3000	CRTT 10000
1	Media chamber tube	87400300	80402300	87404300
1a	Media chamber lid	87400400	80402400	87402400
1b	Media chamber inner tube	87400040	80402040	87402040
1c	O-Ring	80500125	80500200	80500250
1d	O-Ring	93040400	93040400	93040400
2	Gassing chamber tube	87400500	87400500	87404500
2a	Gassing chamber lid	87400600	87402600	87404600
2b	O-Ring 90	80500090	80500090	80500090
2c	DLS Cartridge	87400020	87400020	87404020
2d	Holder plate DSL	87400040	87400040	87400040
3	Control unit without solenoid valve	87406000	87406000	87406000
4	Pump DC 650 4a-f	36007000	36007000	36007000
4a	Stator DC 650	36007100	36007100	36007100
4b	Rotor DC 650	36007200	36007200	36007200
4c	Shaft DC 650	36007300	36007300	36007300
4d	Bearings DC 650 2 pcs.	36007400	36007400	36007400
4e	Housing DC 650	36007500	36007500	36007500
4f	O-Ring DC 650	36007600	36007600	36007600
4g	Filter sponge	87400030	87400030	87400030
4h	Strainer CRTT	87400050	87400050	87400050
5	Non return valve	87140000	87140000	87140000
6	Solenoid valve 12V DC	87408000	87408000	87408000
7	Float switch	87400200	87400200	87404200
7a	Cap nut	93043100	93043100	93043100
7b	O-Ring	93043400	93043400	93043400
9	Recirculation pump DCC2 CR cpl. 9a-c	25073000	25073000	25074000
9a	Stator	26073000	26073000	26074000
9b	Rotor	27073000	27073000	27074000
9c	Bearings	25073001	25073001	25074001
9d	Pump housing	29073000	29073000	29074000
10	Plug	65900000	65900000	65900000
11	Silicone hose white 7/10 1 meter	61760000	61760000	61760000
13	Tap	93010010	93010010	93010010
16	Base plate	87400010	87402010	87404010
17	Ballast 1,75 A	37086000	37086000	37086000
19	Silicone hose white 5/8 1 meter	61758000	61758000	61758000
20	Silicone hose black 4/6 1 meter	61750000	61750000	61750000
M	Flowmeter	87409000	87409000	87409000
M1	Knurled head screw blue short	80600000	80600000	80600000
M2	Holder Flowmeter	87400060	87400060	87400060
M3	Holder screw	87400070	87400070	87400070
21	Vessel	93425000	93425000	93425000
22	Micro filter	64056000	64056000	64056000
23	Pump DC 650 cpl. 4-5, 2x19, 22	36008000	36008000	36008000
24	Adaptor night mode (optional)	87407000	87407000	87407000
25	Adapter plug 5.5 to 3.5 (optional)	87407100	87407100	87407100



Deltec GmbH  
Steller Straße 75  
27755 Delmenhorst  
Germany  
04/2021